

Guided Experiments with Arduino

1pm - 5pm

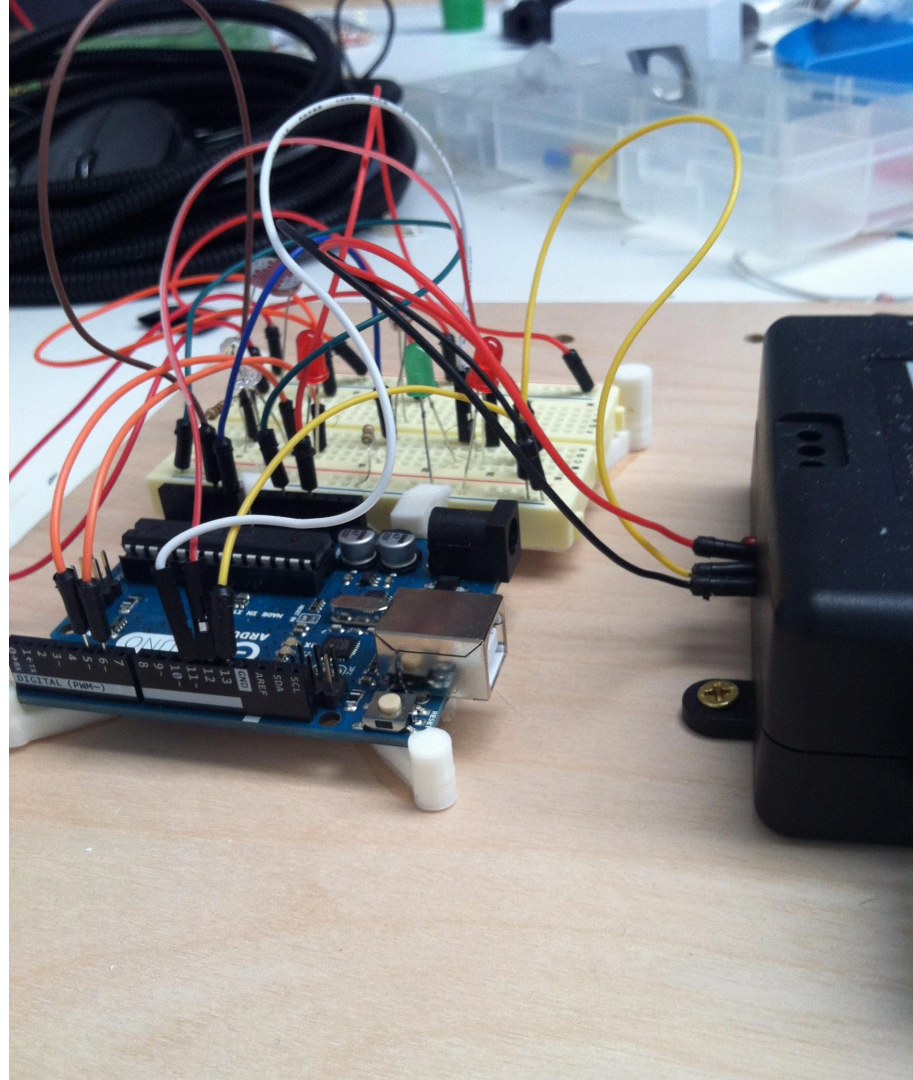

Sensors (input)

Movement

Proximity

Touch

Sound

Temperature

....

Actuators (output)

Movement

Lights

Sound

Visual

...

Sensors (input)

IR Sharps

Photocell

Button

Potentiometer

Force Sensitive Resistors

Camera

Mic

...

Actuators (output)

Servo/DC Motors

Light bulb, LEDs

Play Audio/Video

Screen Display or Projector

Input Data Collection

...

Arduino Pinout

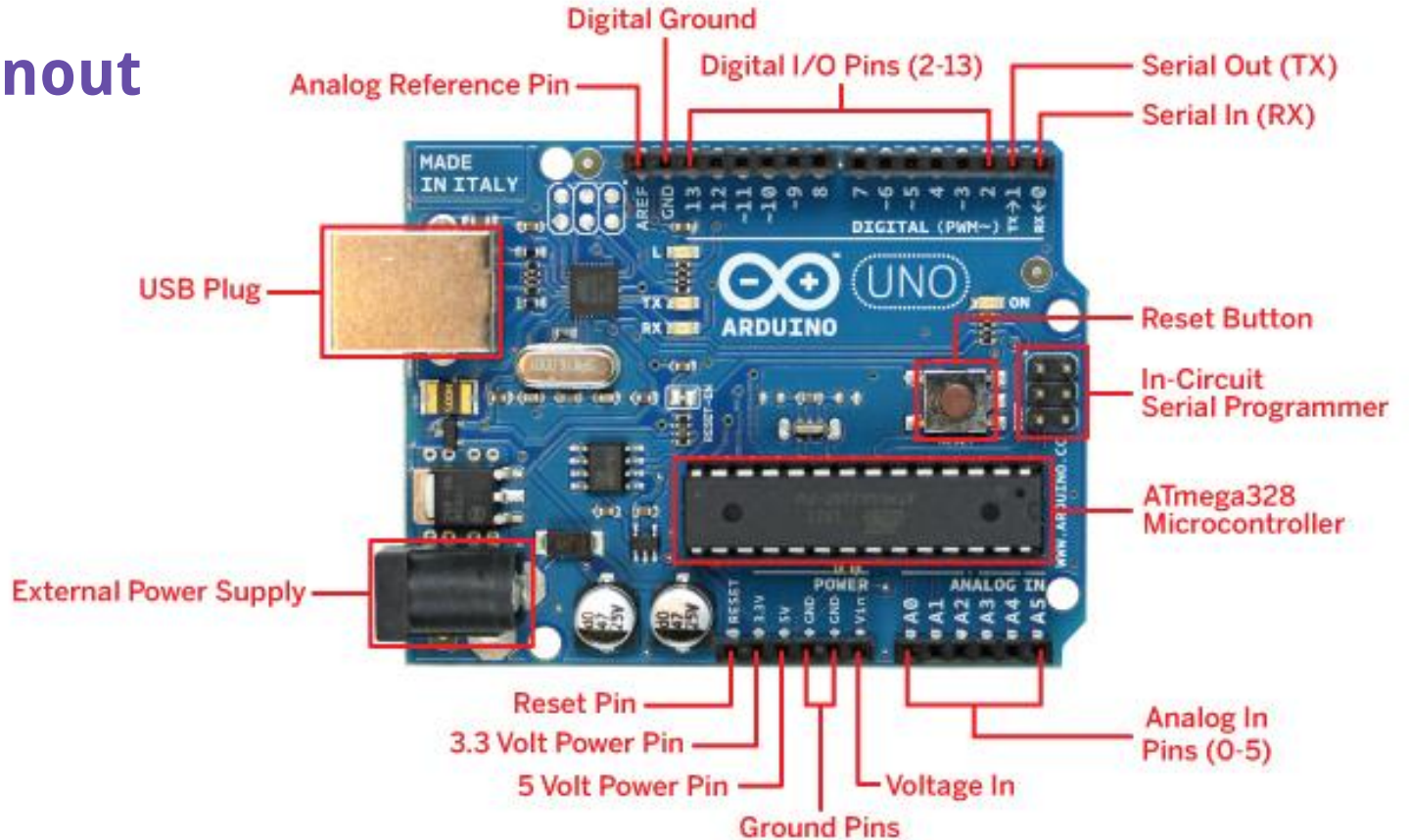

How to use a Breadboard

The outer “vertical bus” is us for power and ground.

All the pins are connected vertically.

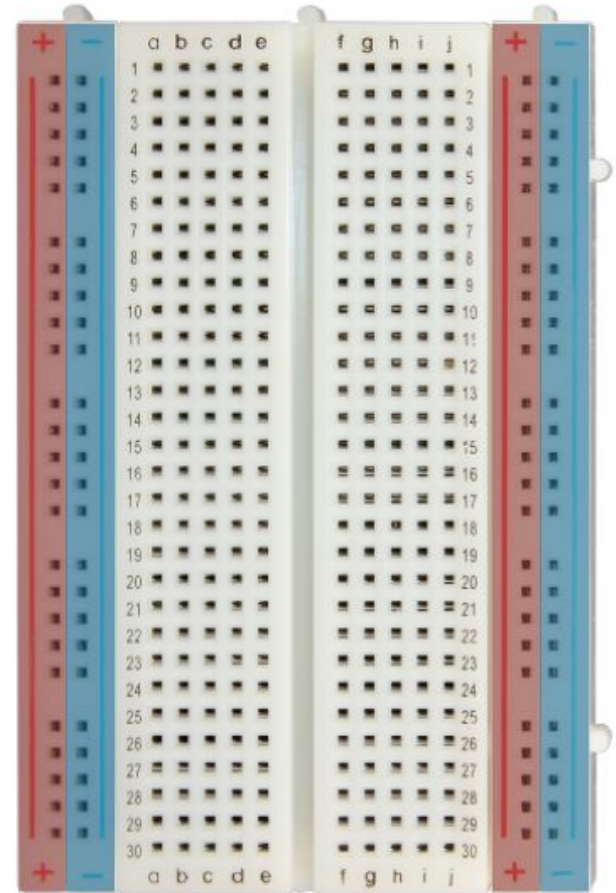
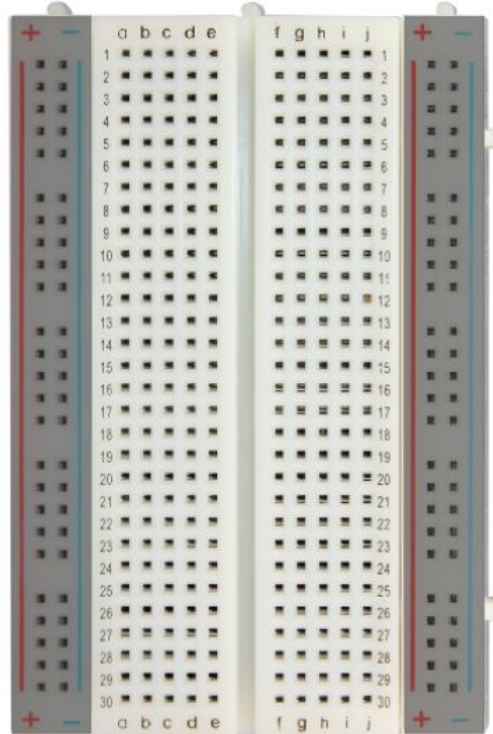

How to use a Breadboard

The inner columns and rows
“horizontal buses”

All the pins on either side of 1
valley are connected horizon

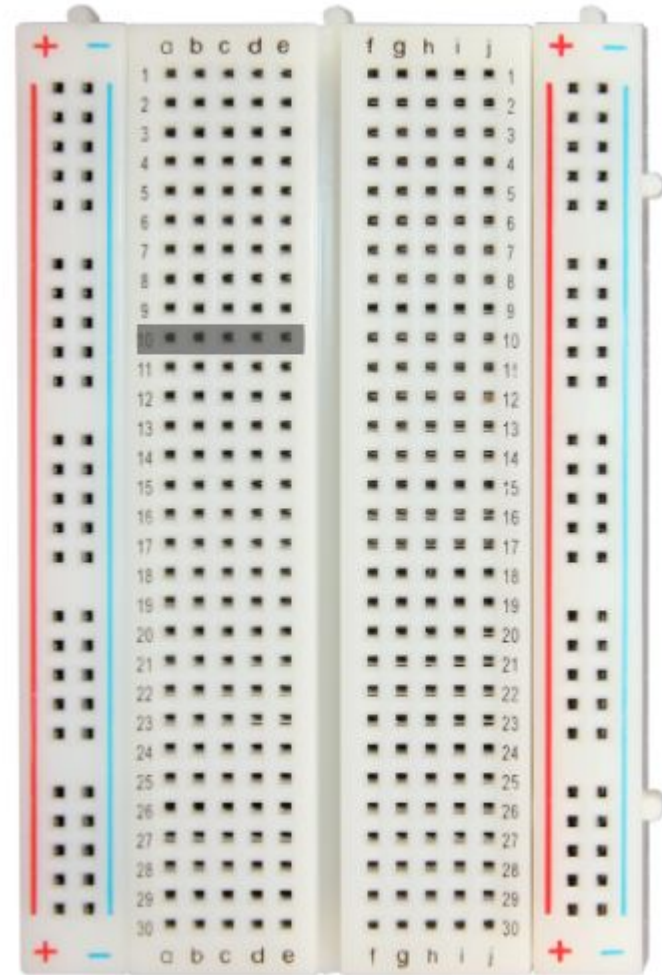
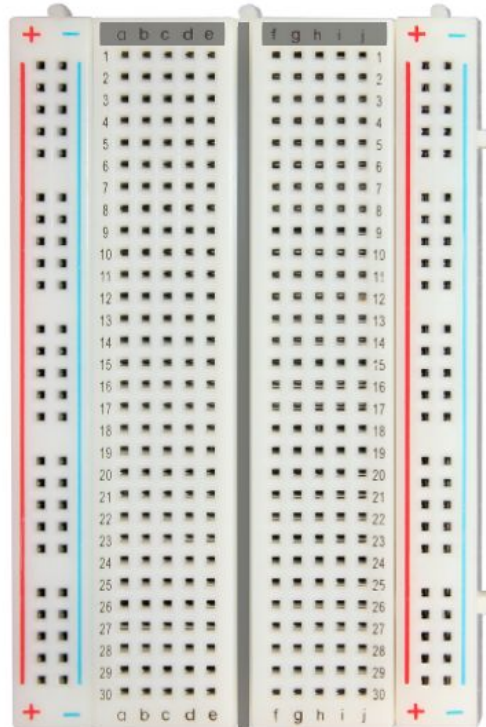

LED (LIGHT EMITTING DIODE)

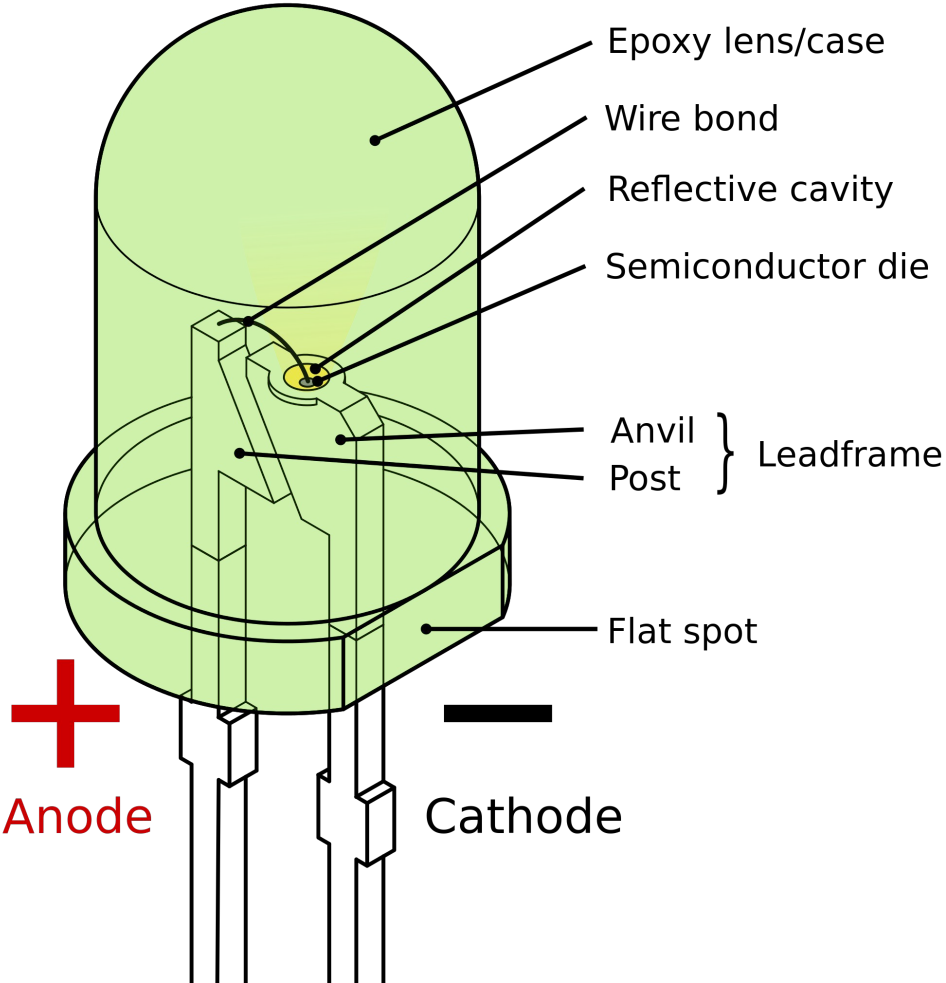
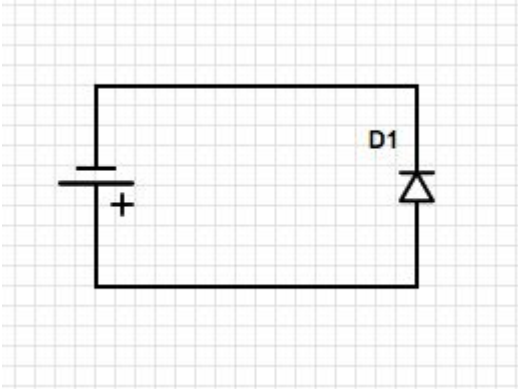

Setup an LED circuit

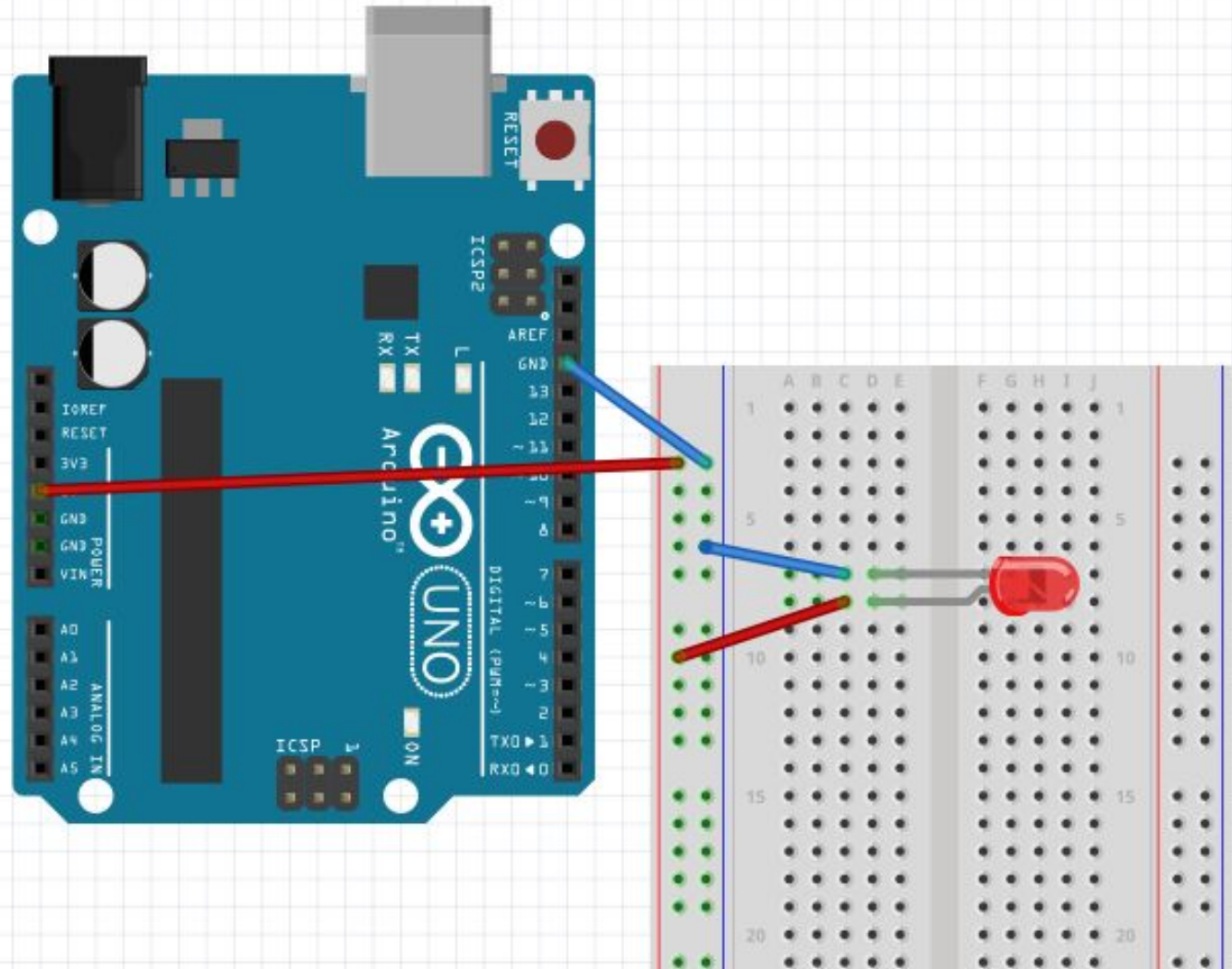

Resistors

Resistors are used to limit the value of current.

$$V = I \cdot R$$

therefore:

$$R = \frac{V}{I}$$

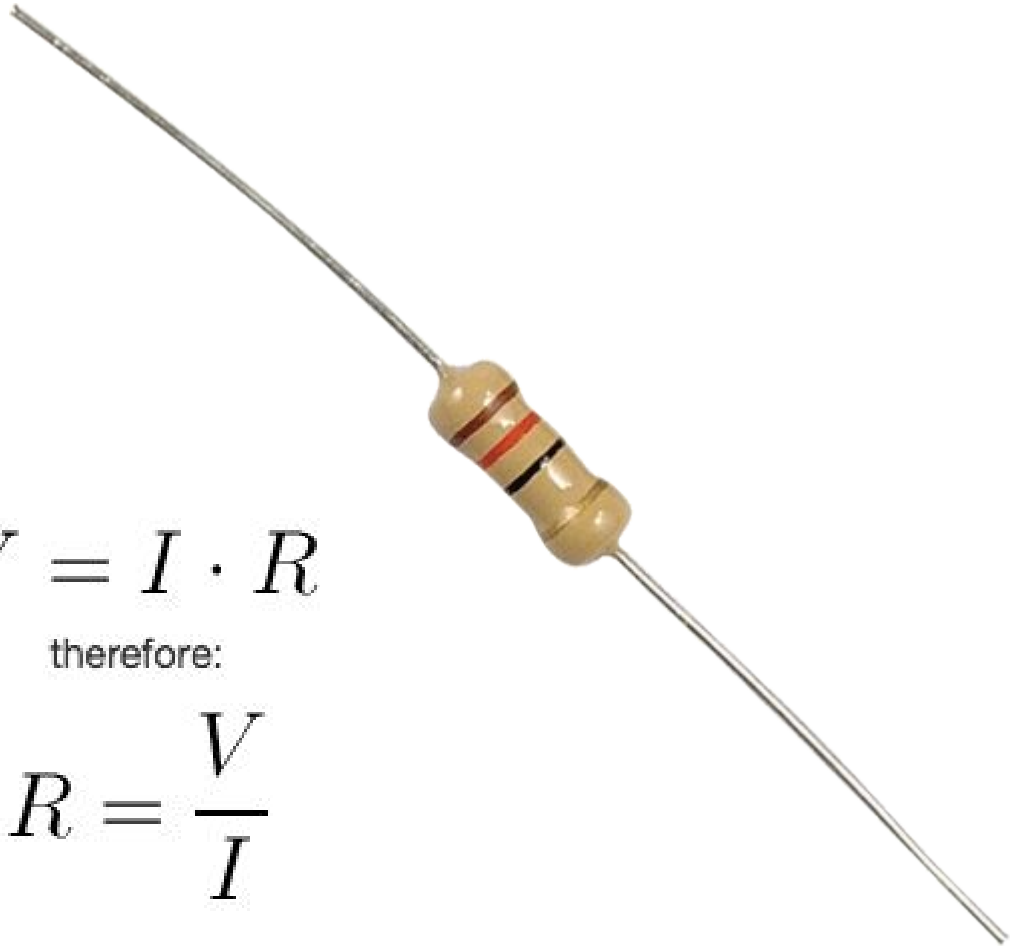

Blink

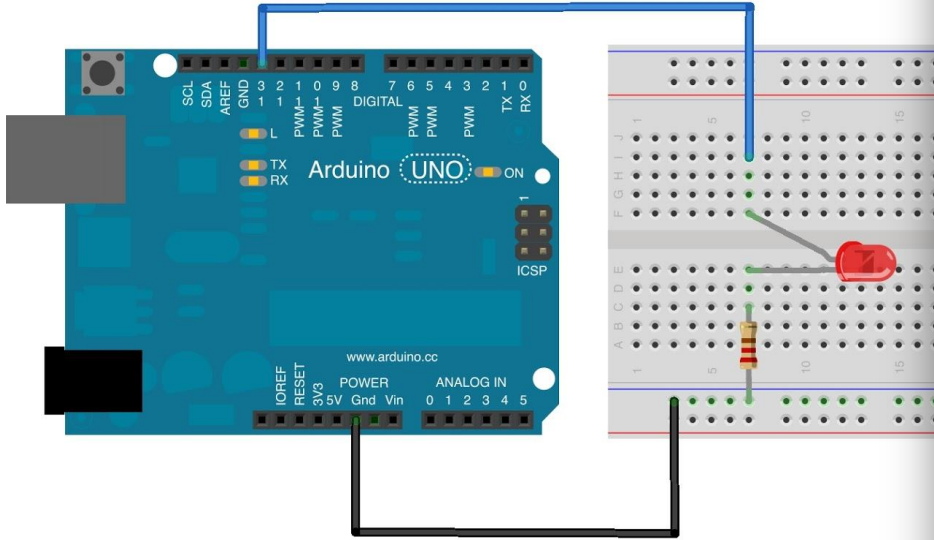

```
Arduino IDE - Blink | Arduino 1.0.5

/*
 * Blink
 * Turns on an LED on for one second, then off for one second, repeatedly.
 *
 * This example code is in the public domain.
 */

// Pin 13 has an LED connected on most Arduino boards.
// give it a name:
int led = 13;

// the setup routine runs once when you press reset:
void setup() {
  // initialize the digital pin as an output.
  pinMode(led, OUTPUT);
}

// the loop routine runs over and over again forever:
void loop() {
  digitalWrite(led, HIGH); // turn the LED on (HIGH is the voltage level)
  delay(1000);             // wait for a second
  digitalWrite(led, LOW);  // turn the LED off by making the voltage LOW
  delay(1000);             // wait for a second
}
```

Blink Syntax

Set variable

```
int led = 13;
```

pinMode(pin,mode)

```
void setup() {  
    // initialize the digital pin as an output.  
    pinMode(led, OUTPUT);  
}
```

digitalWrite(pin, value)

```
void loop() {  
    digitalWrite(led, HIGH); // turn the LED on (HIGH is the voltage level)  
    delay(1000); // wait for a second  
    digitalWrite(led, LOW); // turn the LED off by making the voltage LOW  
    delay(1000); // wait for a second  
}
```

Button

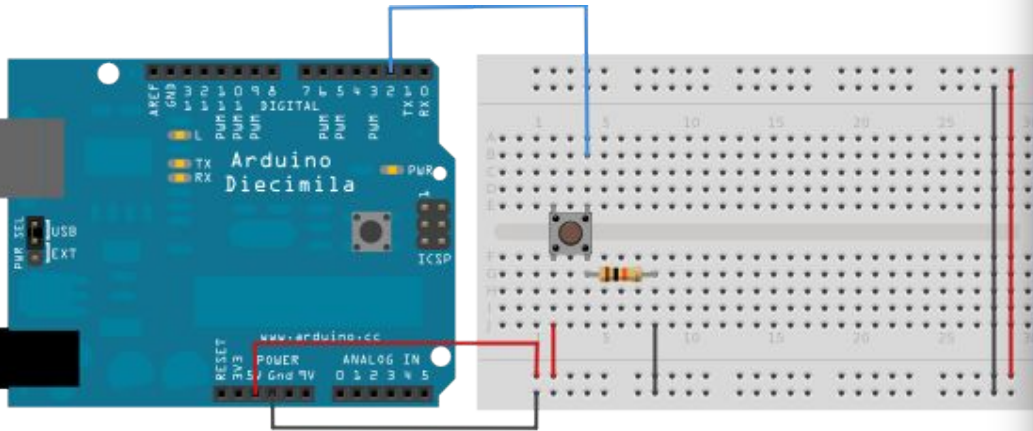

Button | Arduino 1.0.5

Button

created 2005
by DojoDave <http://www.0j0.org>
modified 30 Aug 2011
by Tom Igoe

This example code is in the public domain.

<http://www.arduino.cc/en/Tutorial/Button>

```
*/  
  
// constants won't change. They're used here to  
// set pin numbers:  
const int buttonPin = 2; // the number of the pushbutton pin  
const int ledPin = 13; // the number of the LED pin  
  
// variables will change:  
int buttonState = 0; // variable for reading the pushbutton status  
  
void setup() {  
  // initialize the LED pin as an output:  
  pinMode(ledPin, OUTPUT);  
  // initialize the pushbutton pin as an input:  
  pinMode(buttonPin, INPUT);  
}  
  
void loop(){  
  // read the state of the pushbutton value:  
  buttonState = digitalRead(buttonPin);  
  
  // check if the pushbutton is pressed.  
  // if it is, the buttonState is HIGH:  
  if (buttonState == HIGH) {  
    // turn LED on:  
    digitalWrite(ledPin, HIGH);  
  }  
  else {  
    // turn LED off:  
    digitalWrite(ledPin, LOW);  
  }  
}
```

28 Arduino Uno on /dev/tty.usbmodem1411

Button Circuit

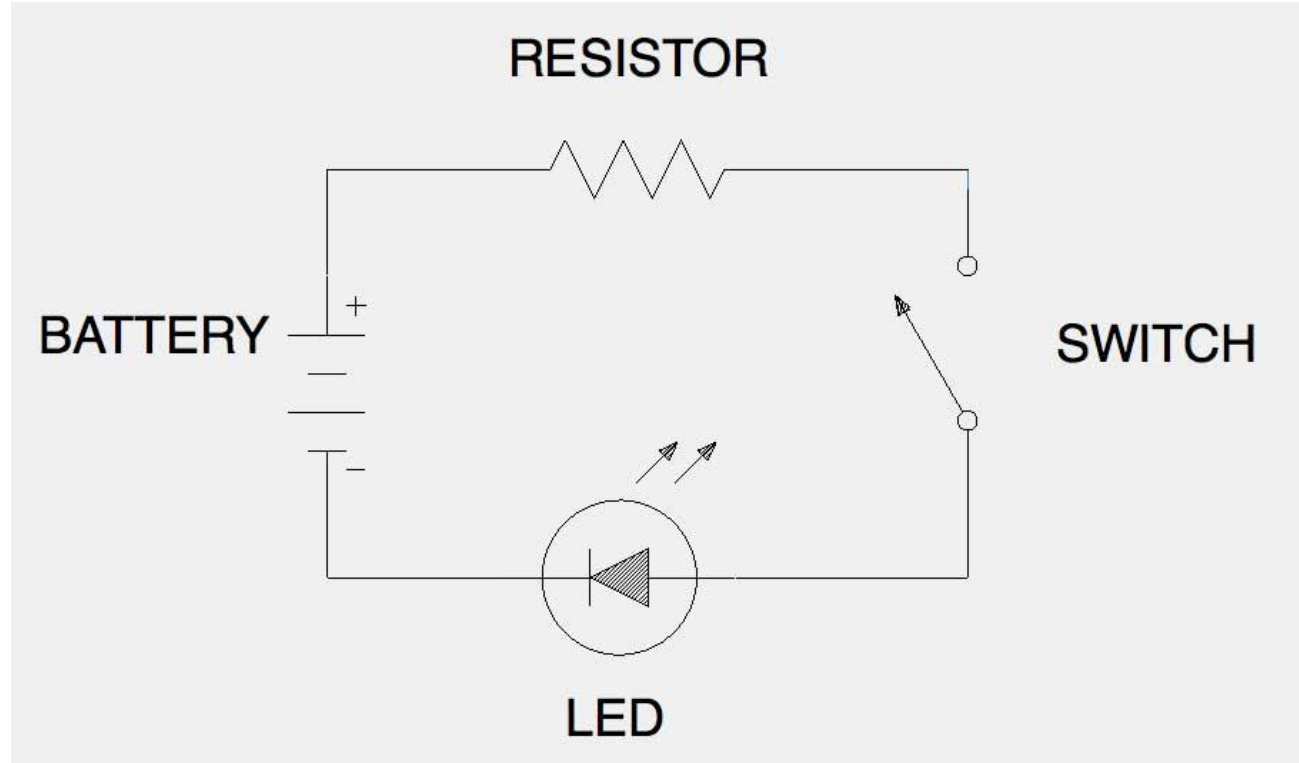

Button Syntax

```
digitalRead(inPin)

if (condition is met) {
    //action A
}
else {
    //action B
}
```

```
void loop(){
    // read the state of the pushbutton value:
    buttonState = digitalRead(buttonPin);

    // check if the pushbutton is pressed.
    // if it is, the buttonState is HIGH:
    if (buttonState == HIGH) {
        // turn LED on:
        digitalWrite(ledPin, HIGH);
    }
    else {
        // turn LED off:
        digitalWrite(ledPin, LOW);
    }
}
```

Analog Input

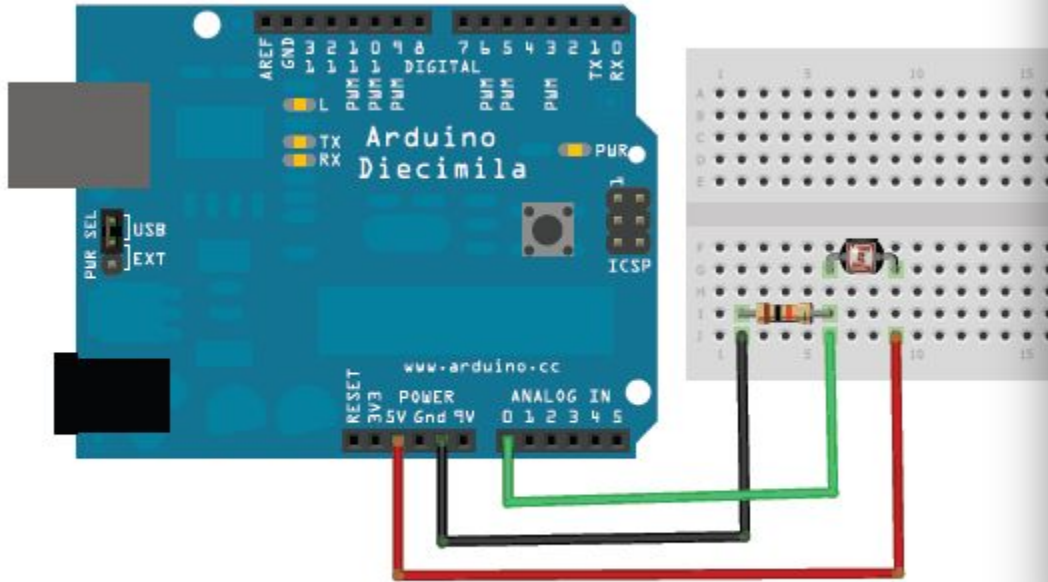

```
AnalogReadSerial | Arduino 1.0.5

/*
 * AnalogReadSerial
 * Reads an analog input on pin 0, prints the result to the serial monitor.
 * Attach the center pin of a potentiometer to pin A0, and the outside pins to +5
 * and ground.
 *
 * This example code is in the public domain.
 */

// the setup routine runs once when you press reset:
void setup() {
  // initialize serial communication at 9600 bits per second:
  Serial.begin(9600);
}

// the loop routine runs over and over again forever:
void loop() {
  // read the input on analog pin 0:
  int sensorValue = analogRead(A0);
  // print out the value you read:
  Serial.println(sensorValue);
  delay(1);        // delay in between reads for stability
}

1 Arduino Uno on /dev/tty.usbmodem1411
```

Analog Syntax

Initialize serial communication

```
Serial.begin(9600);
```

int(0 to 1023)

analogRead(pin)

print to serial

```
int sensorValue = analogRead(A0);  
// print out the value you read:  
Serial.println(sensorValue);
```

Servo

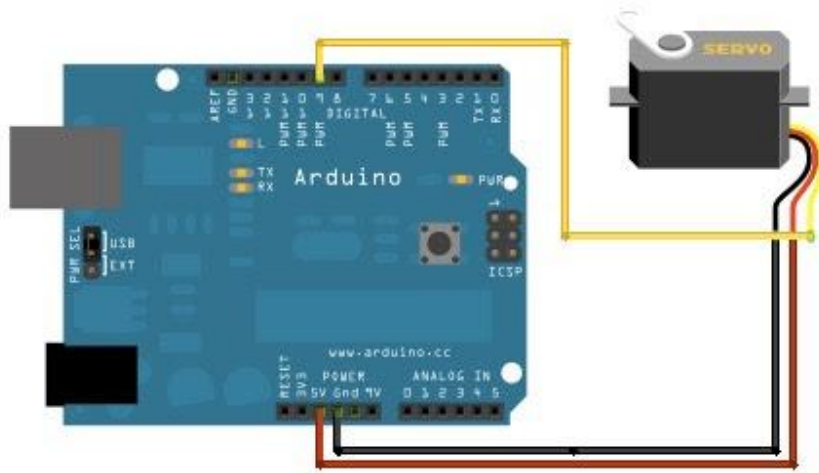

```
Sweep | Arduino 1.7.8
Sweep
9
10 #include <Servo.h>
11
12 Servo myservo; // create servo object to control a servo
13                // twelve servo objects can be created on most boards
14
15 int pos = 0;   // variable to store the servo position
16
17 void setup()
18 {
19   myservo.attach(9); // attaches the servo on pin 9 to the servo object
20 }
21
22 void loop()
23 {
24   for(pos = 0; pos <= 180; pos += 1) // goes from 0 degrees to 180 degrees
25   {                                   // in steps of 1 degree
26     myservo.write(pos);              // tell servo to go to position in variable 'pos'
27     delay(15);                       // waits 15ms for the servo to reach the position
28   }
29   for(pos = 180; pos>=0; pos-=1)    // goes from 180 degrees to 0 degrees
30   {
31     myservo.write(pos);              // tell servo to go to position in variable 'pos'
32     delay(15);                       // waits 15ms for the servo to reach the position
33   }
34 }
35
```

Servo Syntax

Include Servo library

Make a Servo object

Attach signal to arduino pin

Use write method to change degrees in servo rotation

```
#include <Servo.h>
Servo myservo;

void setup()
{
  myservo.attach(9);
}

myservo.write(pos);
```

Where we source our electronics:



Contact

info.ctdl@gmail.com

Rianne | rtruji89@gmail.com

Miles | mtokunow@gmail.com

Museduino.wordpress.com

[#museduino](https://twitter.com/museduino)

